



UG Filtering Technology

EMCignal: meeting the need for ultra-high frequency filtering of high power microwave (HPM) interference and phenomena

White Paper



www.emcignal.com
P.O.B 94, Yavne 81101 Israel
Tel: +972-8-932-7907 Fax: +972-8-858-0980

Table of contents

| | | |
|-------|---|----|
| 1 | Introduction | 3 |
| 2 | Technology overview | 3 |
| 3 | Traditional Filtered Method | 3 |
| 4 | UG filtering Technology | 4 |
| 4.1 | Abstract | 4 |
| 4.2 | Technology Description | 4 |
| 4.2.1 | General | 4 |
| 4.2.2 | Attenuation | 5 |
| 4.3 | Realization | 7 |
| 4.3.1 | Single filter pin module for connector applications | 7 |
| 4.3.2 | Module for Feed-Through applications | 9 |
| 4.3.3 | SMT Component filter | 10 |
| 4.4 | Flexibility | 11 |
| 4.5 | Electrical | 11 |
| 4.6 | Environmental | 11 |
| 4.7 | Accuracy | 11 |
| 4.8 | Typical applications | 11 |
| 5 | Actual performances | 12 |
| 6 | Test set up and measurements | 15 |

1 Introduction

EMCignal has developed an advanced UG filtering technology capable of working at extraordinarily broad frequency ranges, from a few KHz up to tens of GHz.

These new and revolutionary UG products are able to produce nearly linear frequency behavior in the range from 500MHz to above 30GHz.

This new technology is ideally suited to protect electronic systems operating in environments with very high levels of electronic radiation such as avionics systems located in close proximity to the main radar antenna on Navy ships and other similar environments. This technology also protects against High Power Microwave (HPM) electro-magnetic fields which pose a serious threat to both military and commercial utility equipment.

2 Technology overview

The filter connector was populated with two types of filters that were built in series within the same connector shell.

The traditional filter technology was placed in the vicinity of the mating side of the connector with the UG filter technology being placed in the vicinity of the rear side.

Both technologies are using the connector body (shell) as the reference GND for their filter performances and each filter is connected between contact pin/sockets and the reference GND (the connector shell that is bonded to the system box-chassis)

3 Traditional Filtered Method

Filtered connectors, standard feed-through filters and “on board filters” are the most established and well-known technologies typically implemented to deal with filtering demands.

Most of the above mentioned solutions are assembled from standard materials and components such as PCB (FR-4 material) and SMT capacitors (X7R or NPO materials) which are used as the shunt element and shielded beads (ferrite material) which are used as the series element. Typically these filters were built in the form of PI sections.

The filter construction and ground connection enable the filter to have a broad frequency range up to 1GHz and even 2GHz, however at higher frequencies the filter performance begins to degrade. The degradation is caused by a number of inherent and naturally occurring interference characteristics such as: 1) the Electrical Series Resistance (ESR) of the capacitors (which is proportional to the material properties and capacitor case); 2) the bypass capacitor (in-out) caused by “crosstalk” between the contact pins/sockets, and 3) the electrical impedance of the ground (GND) connection. As a result of these interference characteristics the filter performance at the 1GHz frequency is limited to about 50db.

At higher frequencies the filter completely stops working because of the interference characteristics and the signal losses which occur in the ferrite beads.

Fig 1. below shows a traditional structure of Filtered Connector.

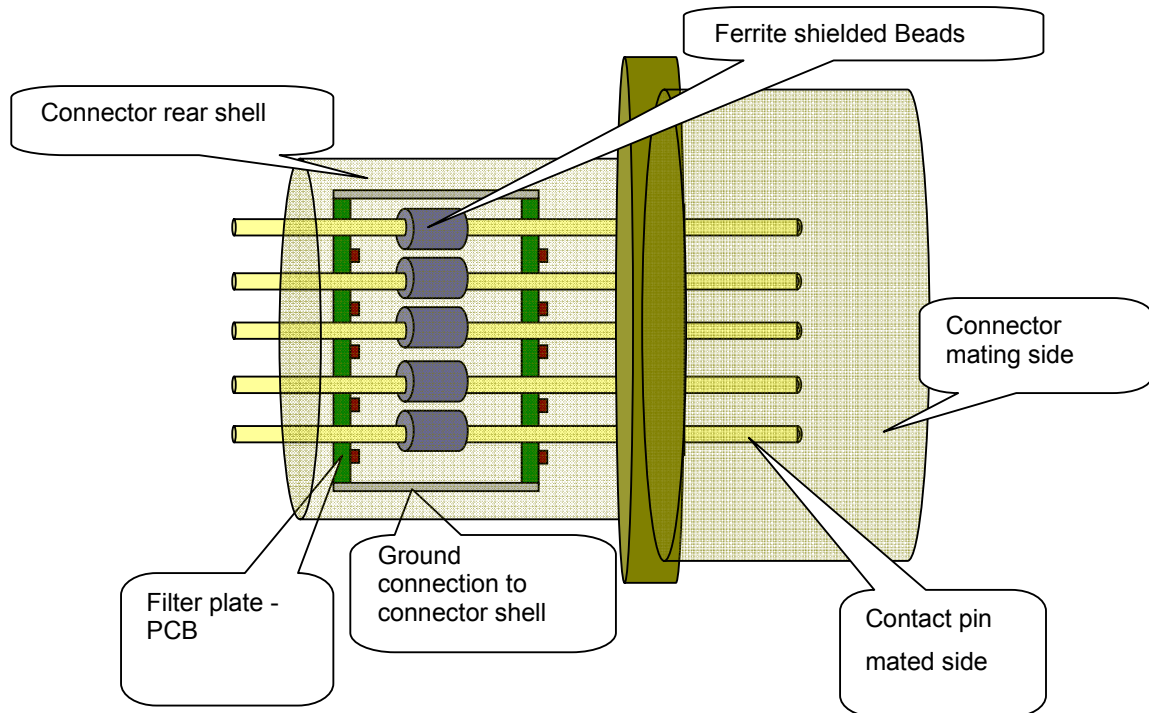

Fig 1 – Traditional filter connector

4 UG filtering Technology

4.1 Abstract

EMCignal has developed a new and innovative technology for filtering in the ultra high frequency range (above 1 GHz), called “**UG series**”.

UG technology can be successfully implemented into electronic systems to protect against High Power Microwave (HPM) electro-magnetic fields as a stand-alone filter, in feed-through configuration, in filtered connectors, or as a single component.

This technology is the most reliable and most cost effective solution for all types of signals, including power lines, video & audio lines, communication applications, as well as balanced and un-balanced signals (which require significant attenuation at very high frequencies)

4.2 Technology Description

4.2.1 General

EMCignal’s new technology utilizes advanced materials in combination with new filtering techniques and is based on super attenuation properties of amorphous materials at microwave frequency band combined with maximum interaction between the magnetic field and the filter core structure.

The result is an “immunization” of board circuitry by incorporating this technology with microelectronics.

The UG technology is divided into two series of products based on the application:

- UGA series – for small signal lines, less than 250 mA, to provide high attenuation (more than 50dB) over the frequency range from 1GHz to 20 GHz and beyond. This is a perfect solution especially for Common Mode filters.
- UGT series – for high current, up to 20 A, to provide attenuation (more than 40 dB) over the frequency range of 1GHz to 20 GHz and beyond.

4.2.2 Attenuation

The new EMCignal filter technology covers a wide frequency range starting at 100MHz and going up to 30GHz and higher with extremely high attenuation performance (measured: >60db up to 20GHz) especially for common mode filter types and configurations.

By using a combination of UG technology and standard filter technology the frequency range can be expanded, starting at less then 100 KHz.

The following diagrams demonstrate the results which were recorded on UG filters in the form of “UG Feed-Through”

The testing was performed in a cylindrical configuration with each filter (feed-through) being placed into that fixture. RF adapters were used in order to combine traditional and UG filters. Test set up is shown in paragraph 6.

Fig 2 shows the insertion loss of several UGA types measured at the frequency range of 1GHz to 20GHz (limitations of the signal generator – limited to 20GHz).

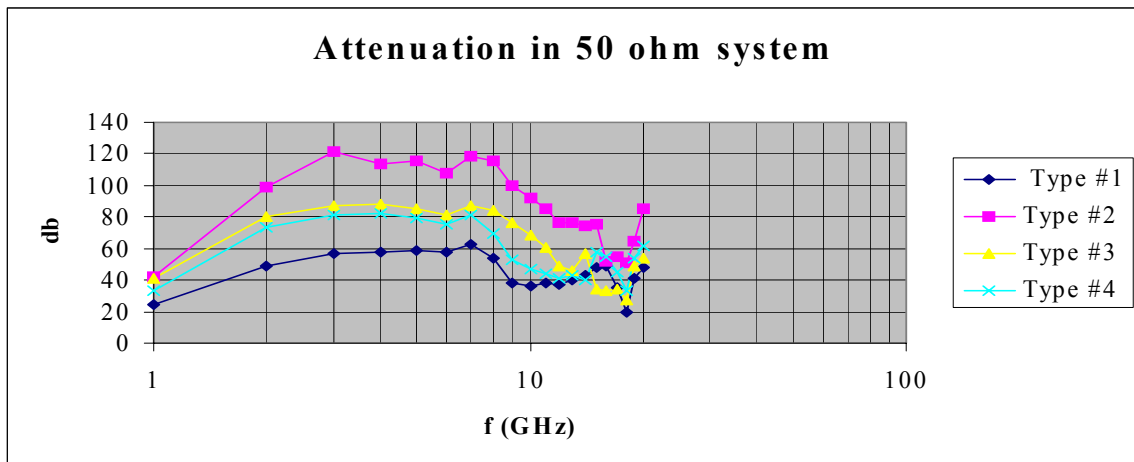

Fig 2 Insertion Loss

Fig 3 shows the results of combined filter – a UGA filter together with standard 1nf “PI” type filter.

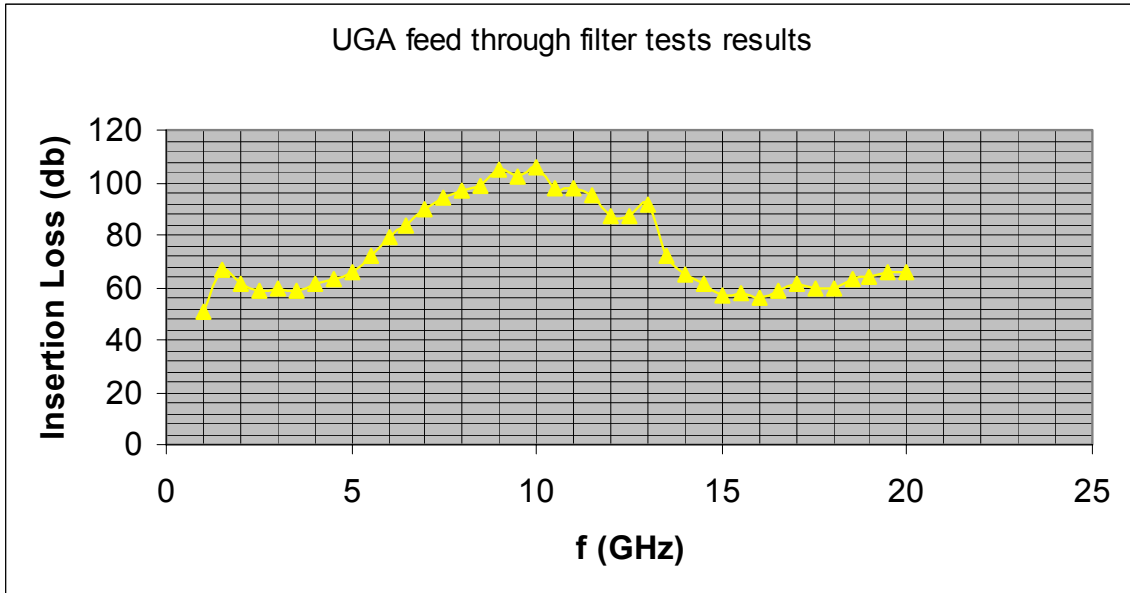

Fig 3 – UGA together with standard 1nf “PI” filter.

Fig 4 shows the insertion loss of several UGT types measured at the frequency range of 1GHz to 20GHz (limitations of the signal generator – limited to 20GHz).

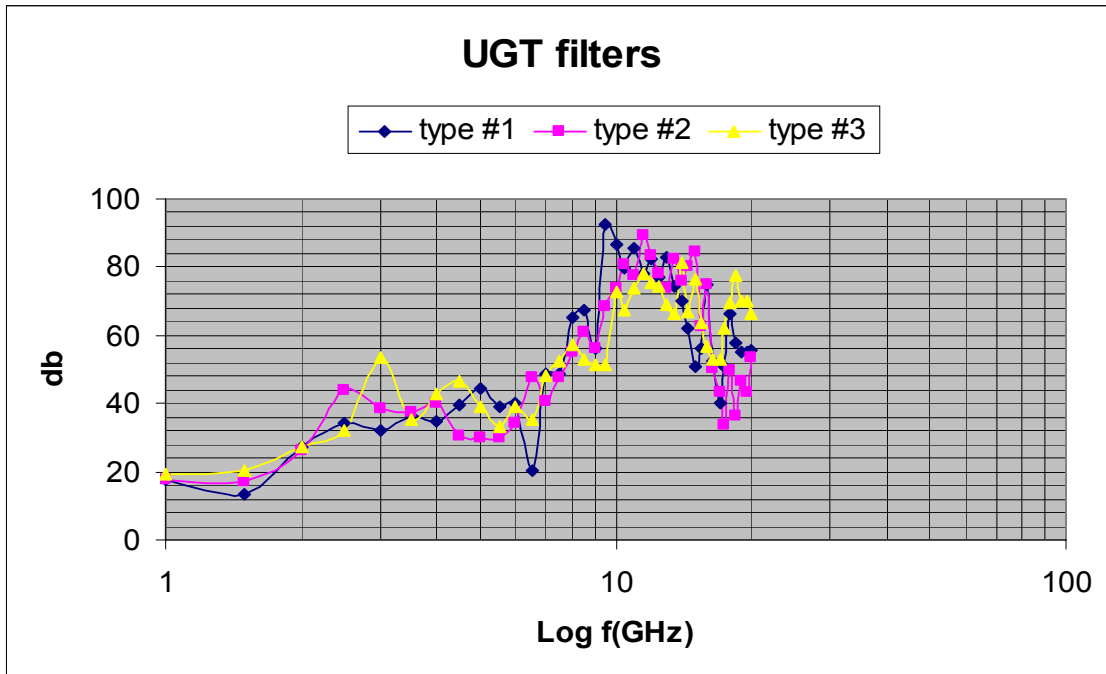

Fig 4 – UGT Insertion Loss

Fig 5 shows the results of combined filter –a UGT filter together with standard 1nf “PI” type filter.

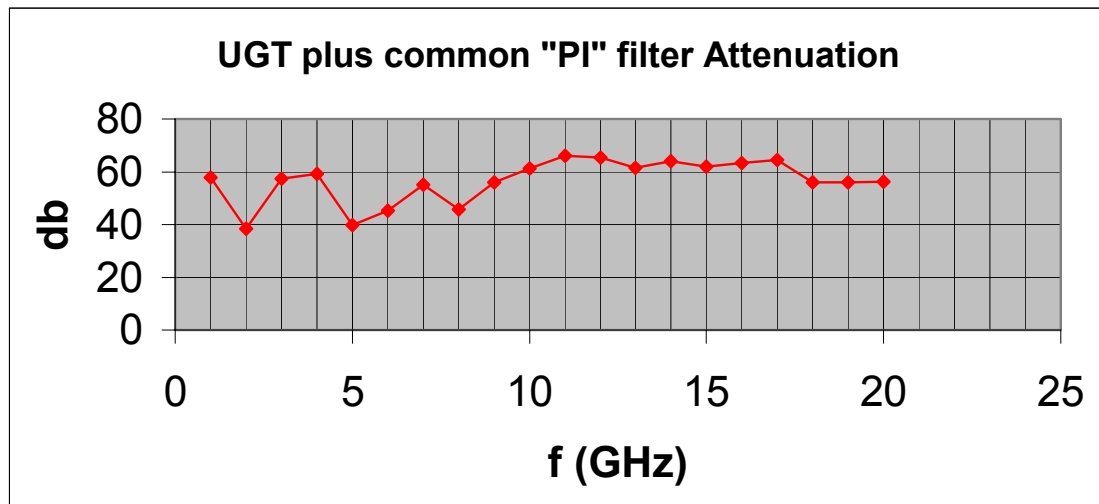

Fig 5 – UGT together with standard 1nf “PI” filter.

4.3 Realization

This technology can be realized by combining several different configurations of varying performance based on the end-application.

4.3.1 Single filter pin module for connector applications

The single filter pin module is designed for ultra high frequencies and intended to be assembled in the connectors.

This solution could be based on UGA and/or UGT techniques as well as in combination with standard filtering technologies (planar, tubular etc.) The configuration of the UG module is very similar to the existing tubular filter pin.

Fig. 6 describes the UG filter pin module installed into a circular connector.

In this instance the minimum diameter of the module is 3mm which fits the #20 arrangement and part of the #22 arrangement. In the near future, all of the #22 arrangements will be available.

NOTE: The minimal length of the filter module is approximately 8 mm.

Fig. 7 depicts the schematic for a single filter pin assembly consisting of the filter section as well as the terminations. The connector mating end can be either a pin or socket with the termination being PCB tail or solder cup.

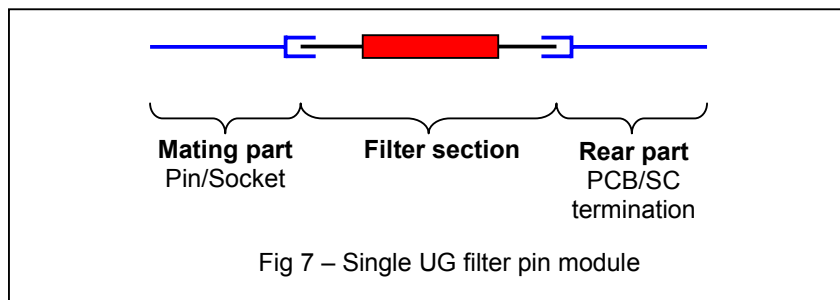
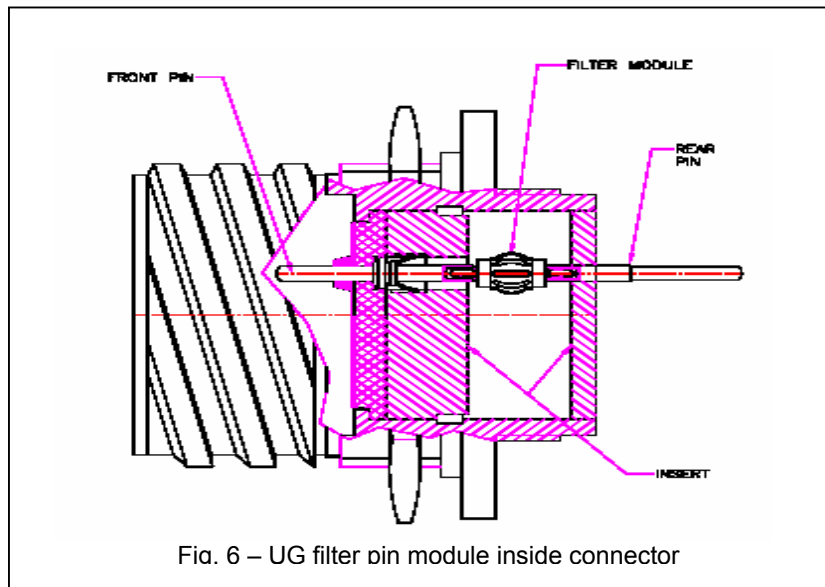

Fig. 8 is an actual picture of a UG filter pin module that was installed in M83723/74R20418 and MS 3474L2041S connectors. It shows the filter section and the tin plated (over gold) contacts on both sides.

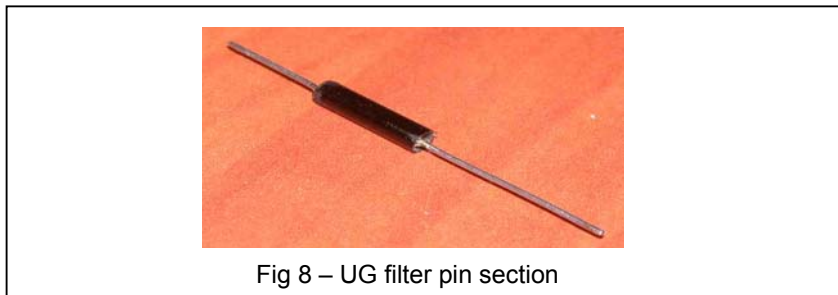
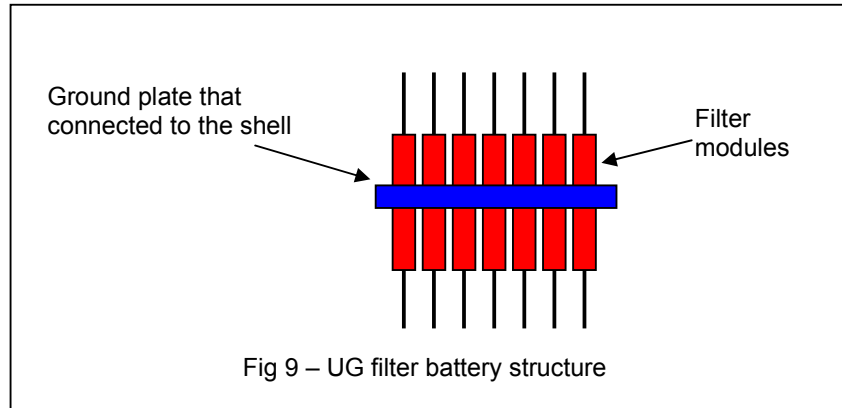
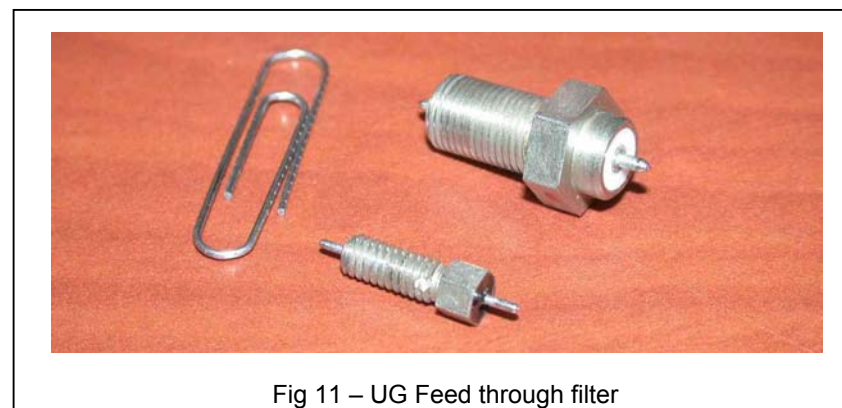
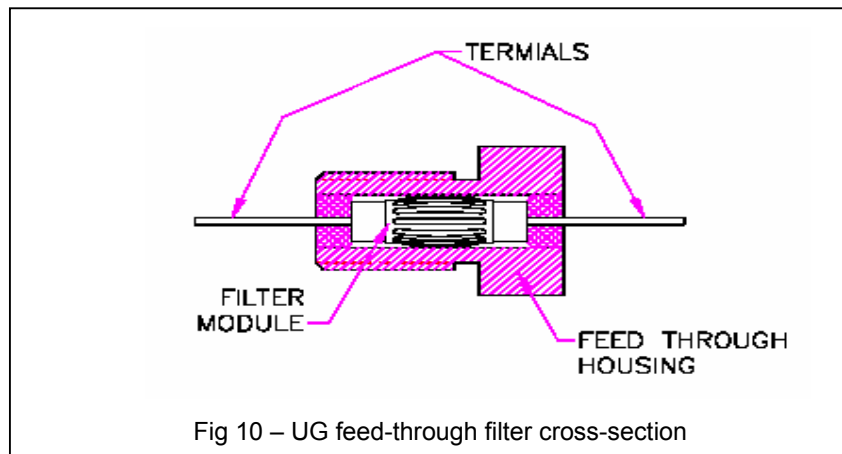

Fig 9 shows an assembly of UG filter contacts to a grounding plate that provides sufficient grounding to the filter.



4.3.2 Module for Feed-Through applications

UG technology can be implemented in common feed through filter housings. Fig 10 and 11 demonstrates the inner structure of the UG Feed-through filter.



4.3.3 SMT Component filter

UG technology can be implemented in SMT applications. Fig. 12 demonstrates two variations of SMT products.

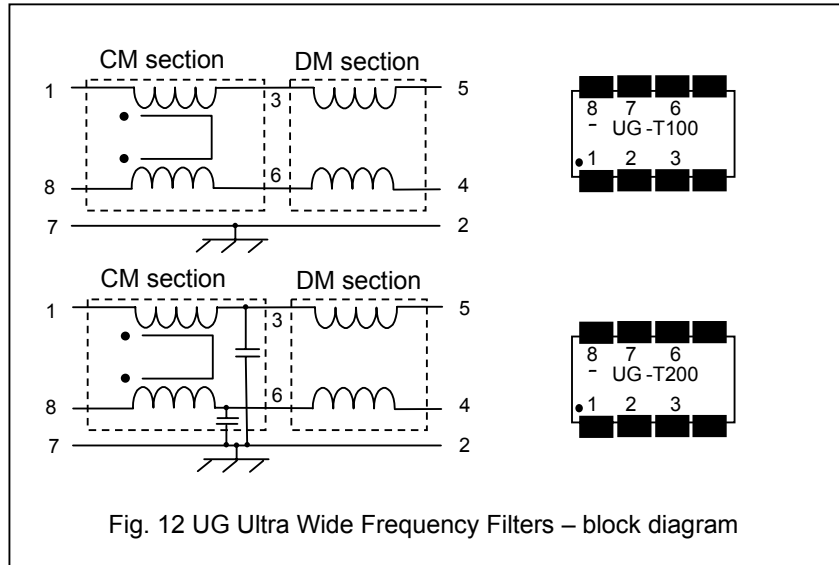

The table 1 below shows the environmental ranges of the SMT component:

Table 1

| | Commercial | Military |
|--------------------|-------------------------|-----------------------------------|
| Temperature | | |
| Operating: | -20°C to 85° | -40° to 105° |
| Storage: | -20°C to 85° | -45° to 125° |
| Thermal shock: | N/A | -40° to 85° in 5 minutes |
| Dynamic | | |
| Vibration sine: | 10 g PTP up to 500 Hz | 10g PTP up to 500 Hz |
| Vibration random: | 20 g RMS, 20 to 2000 Hz | 20 g RMS 20 to 2000 Hz |
| Shock: | 40 g X 11 msec | 40 g X 11 msec |
| Climatic | | |
| Humidity: | Up to 95% R.H | Up to 95% R.H |
| Chemicals: | Common used solvents | Common used fluids and hydraulics |

4.4 Flexibility

The new technology is highly flexible and versatile which means it can be applied as a CM filter for two or more contacts, as well as a DM filter. It may be implemented for a single-pin filter or multi-contact filter with specific filter values for each contact.

It may also be applied to filter connectors where the individual contact pins have their own filter type and level given the same connector sizes and construction.

4.5 Electrical

UGA technology is most suitable for small (low) signal lines (balanced, unbalanced, etc.) The saturation current is limited to a maximum of 1.5Amps for a single pin filter and is unlimited for common mode filters.

UGT technology is most suitable for large (high) signal lines (balanced, unbalanced, etc.) The saturation current is almost unlimited. It was tested to 20Amps for a single pin filter.

Both UGA and UGT have a working voltage of more than 500VDC.

4.6 Environmental

Basically the environmental characteristics are dictated by the housing construction.

4.7 Accuracy

The filter accuracy is as high as 1%.

4.8 Typical applications

UG technology is appropriate for applications such as:

- Extremely high electro-magnetic radiation as detailed in MIL- STD- 464
- Wireless Telecom equipment. LAN: Ethernet & fast Ethernet, wireless LAN (802.xx.y)
- Wired (land-line) Telecom market, such as xDSL and ISDN
- Systems that are sensitive to cellular frequency
- Protection against HPM interference and phenomena

5 Actual performances

The filters that have been used in this test are UGT because they are specifically designed to work with high load currents (more than 5A)

The tests were performed given two forms of filter construction:

- Filter in the form of feed-through
- Filter connector

Measurements that were performed on the feed-through verified the technology while the measurements that were performed on the connector were done only on one contact pin/socket so as to preserve the coaxial geometry of the test set up.

Fig. 13a and 13b – shows the actual filter performances at frequency range 1GHz to 20GHz.

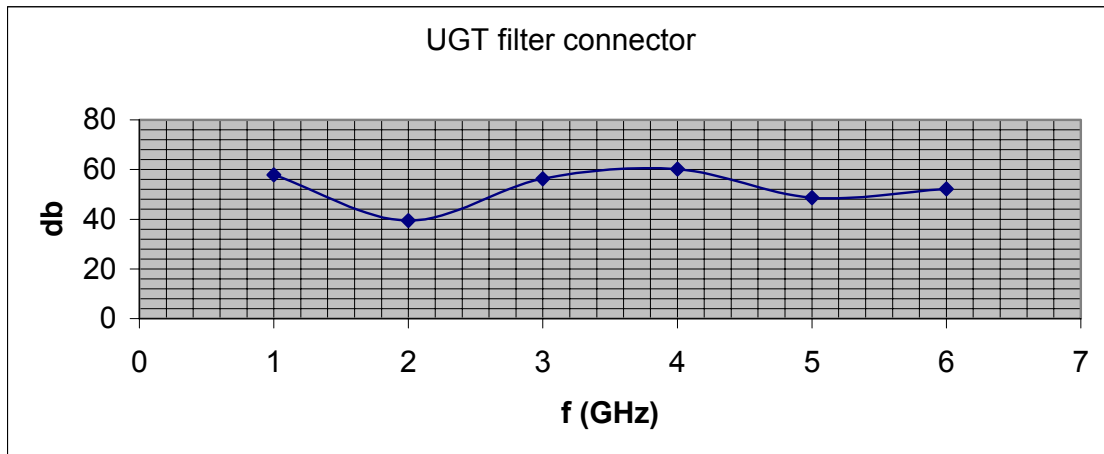

Fig. 13a – results at 1GHz to 6GHz

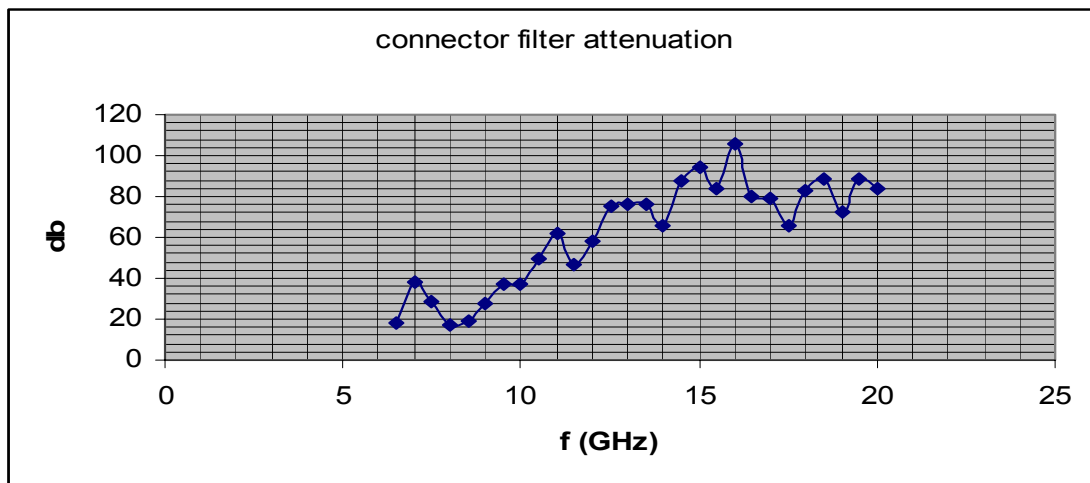

Fig.13 – results at 6GHz to 20GHz

Figures 14a and 14b – shows the actual filter performances at frequency range up to 1.8GHz.

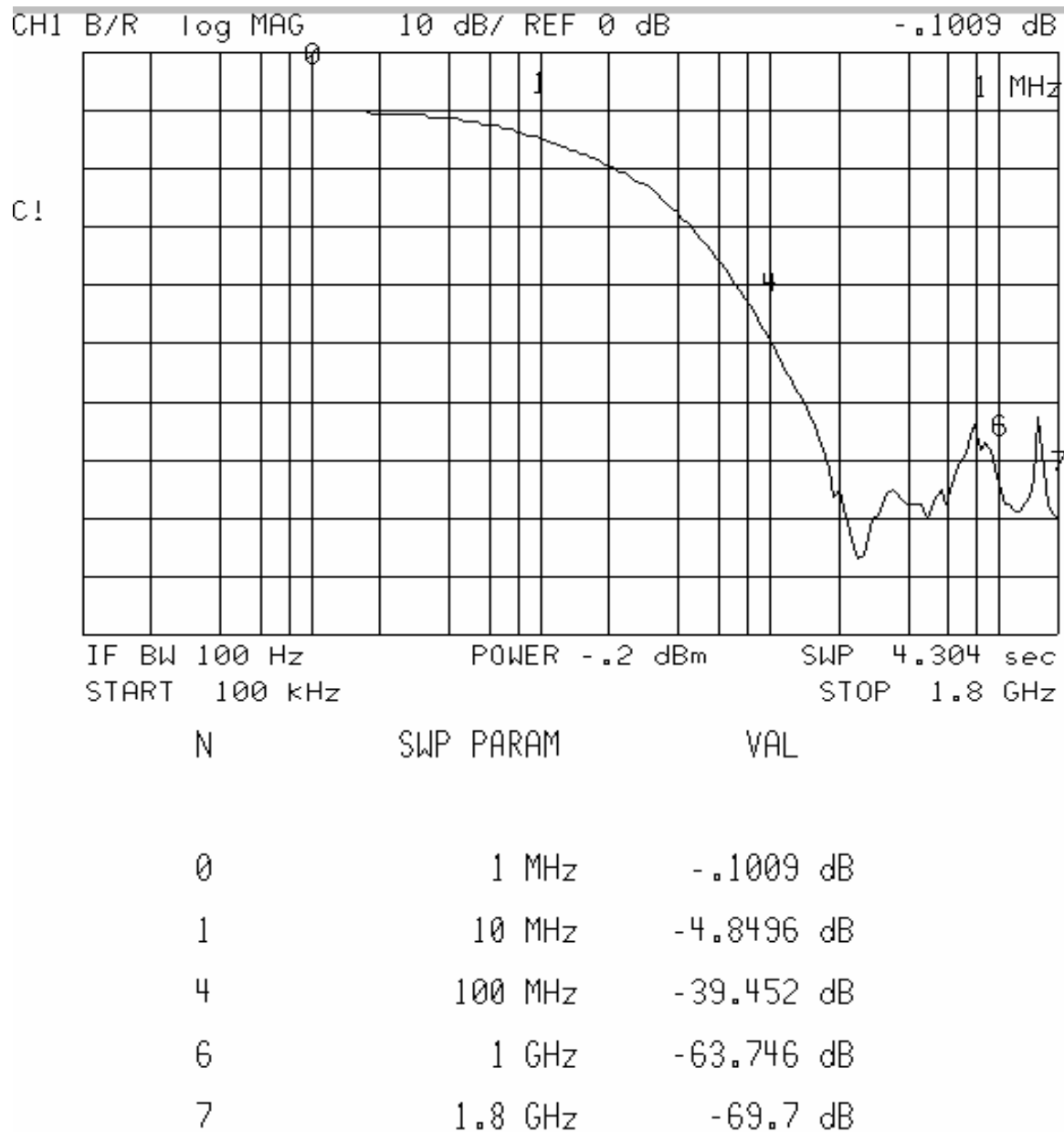

Fig. 14a – results of contact with 1nf PI & UGT filters

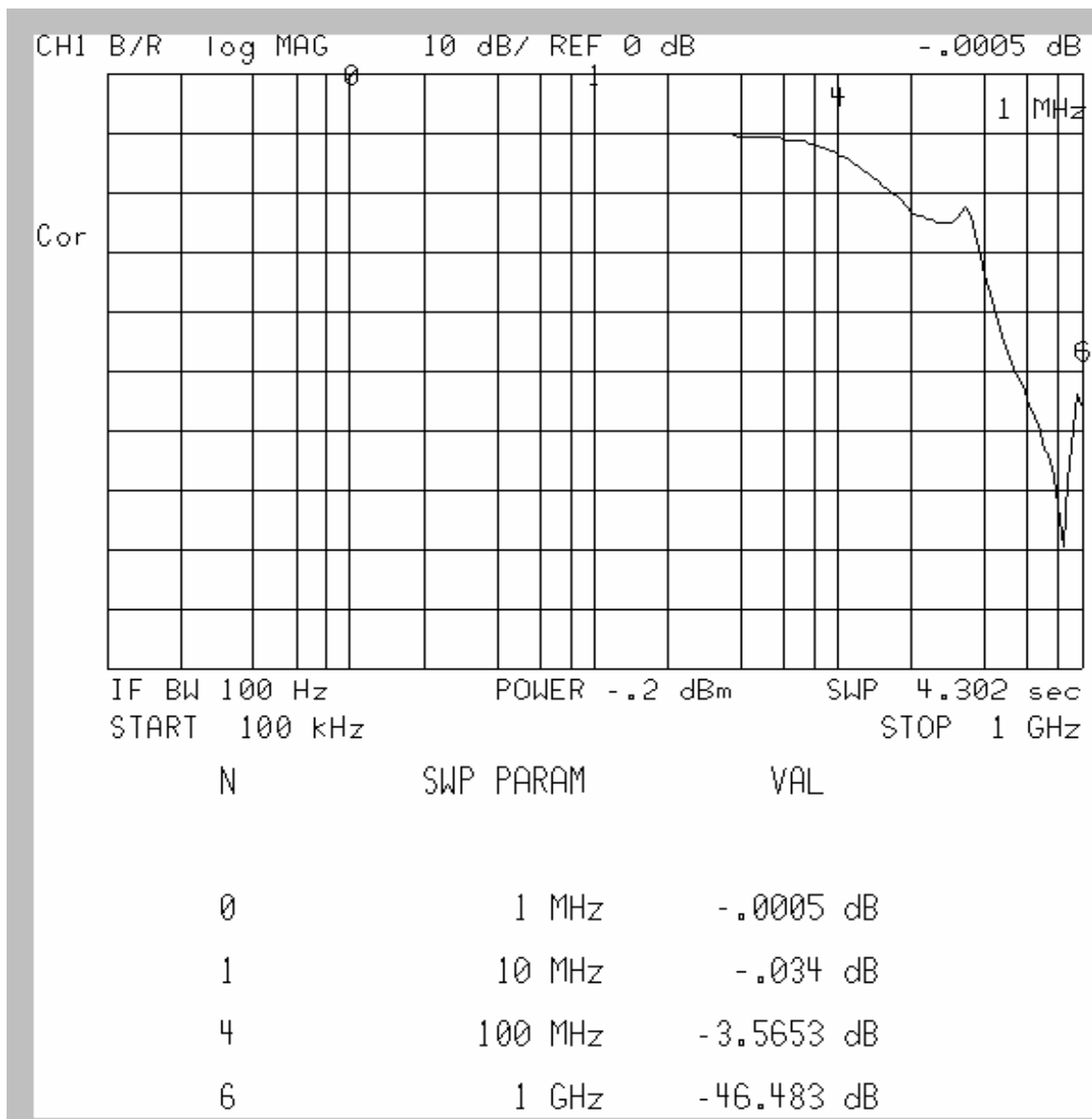

Fig. 14b – results of contact with 100pf PI & UGT filters

6 Test set up and measurements

Measurements were taken on a test fixture that was designed to work at frequencies above 1GHz. It was designed to have a characteristic impedance of 50Ω and to avoid any cross-talk/leakage at that frequency range.

Measurements of reference contact (not filtered) were recorded prior to the filter measurements.

Fig. 15 – shows the test set up for measurements of UGA technology

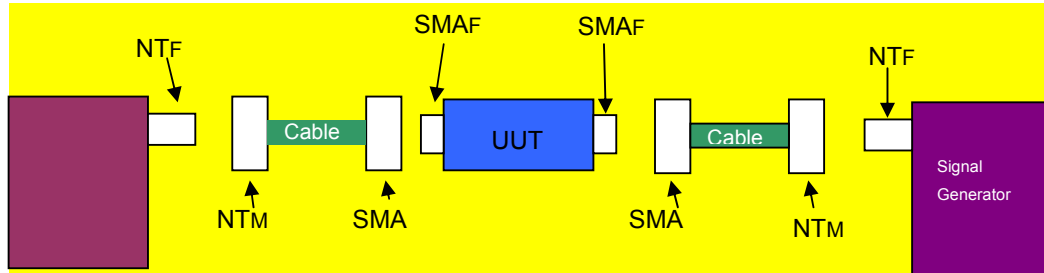

Fig 15

Figure 16 – shows the test set up for measurements of UGT technology

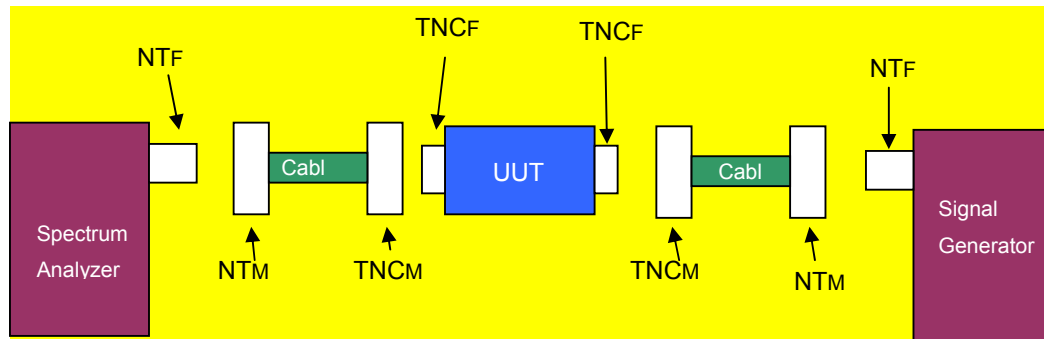

Fig. 16

Figure 17 – shows the reference results of UGA measurement

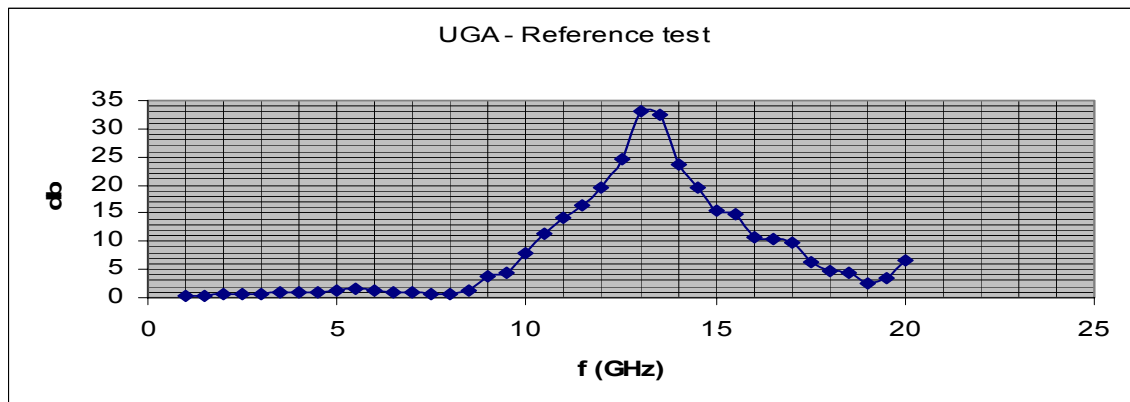

Fig. 17

Fig. 18 – shows the reference results of UGT measurement

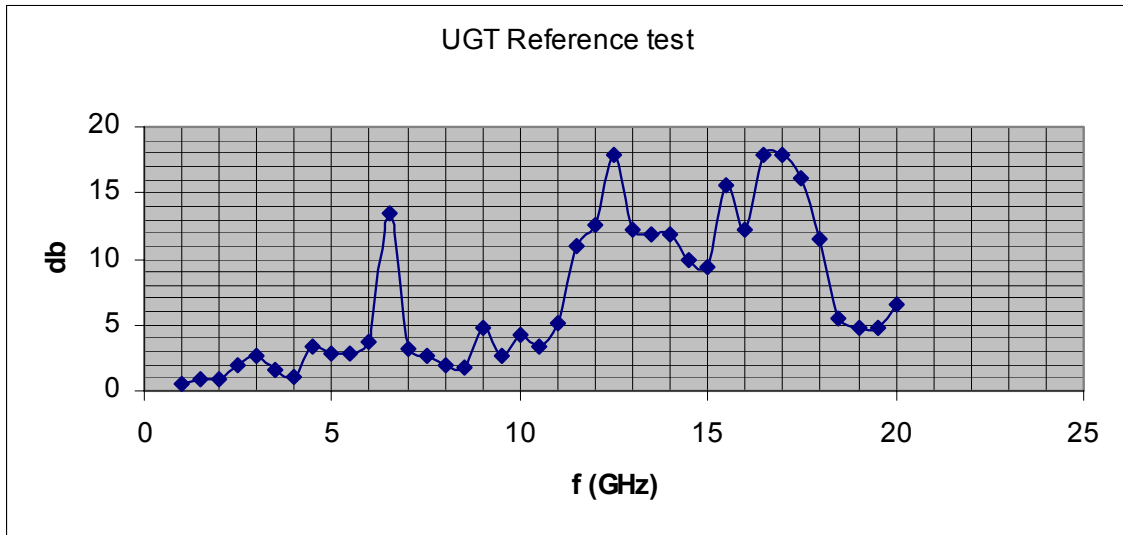

Fig. 18

Fig. 19a and 19b – shows the test set up of the complete connector measurements



Fig. 19a



Fig. 19b

Fig. 20 – shows the reference results of connector test set up measurement

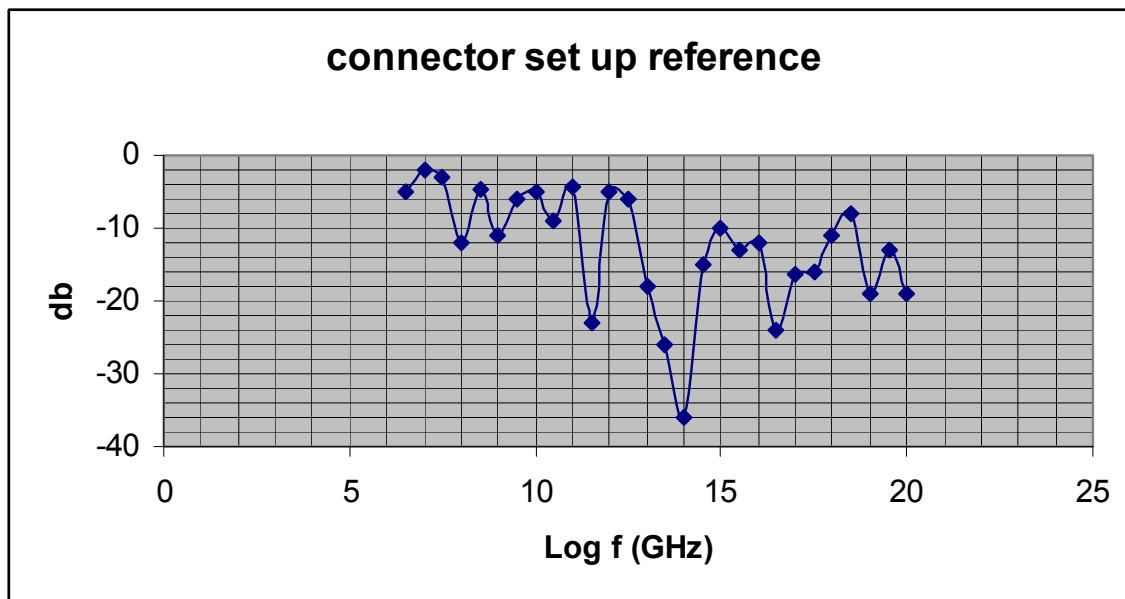

Fig. 20

Table 2 details the equipment test set up

Table 2

| Test equipment name | Test equipment model | Frequency range |
|------------------------------|----------------------|-----------------|
| Spectrum network analyzer | HP4936A | 10Hz – 1.8GHz |
| EMC analyzer | E7405A | 100Hz – 20.5GHz |
| S parameter network analyzer | 8753ES | 30KHz – 6GHz |
| | | |